

RMG 330 gas pressure regulator



PRODUCT INFORMATION

**Serving the Gas Industry
Worldwide**



Gaspressure regulator RMG 330

Applications, Features, Technical Data

Application

- Direct-acting gas pressure regulator (GPR) (working without auxiliary power) with incorporated SSV for commercial and industrial gas installations as well as local supply systems
- Particularly well-suited for dynamic processes (e.g. gas furnaces, burner circuits, gas engine operations)
- Can also be used as an equipment part for gas consumer facilities pursuant to EC Directive (90/396/EWG)
- As gas pressure regulator with electrical setpoint follower (motorized actuator) and pneumatic setpoint follower
- Can be used for gases according to DVGW worksheet G 260 and neutral non-aggressive gases; other gases upon request

2

Features

- Design inherently pressure-tight (IS)
- GPR with integrated SSV, optionally SBV for gas leakage quantities as well as variant with safety diaphragm
- Large inlet pressure range
- Installation of different valve seat diameters possible
- Maintenance-friendly due to replaceable functional units (pluggable design)
- SSV optionally function class A or B
- Pressure compensation valve (inner circumference) incorporated in SSV actuator

Variants, optionally

- Without SSV
- With SSV - manual triggering
- With SSV - electromagnetic remote triggering
- With electrical position display for SSV "Closed" using inductive proximity initiator and intrinsically safe power circuit
- Regulator system with leakage gas SBV (p_D up to 0.5 bar) or safety diaphragm
- With RMG 915 breather valve (SSV/RE) or RMG 919 switching valve (SSV)
- With noise reduction

Specification						
Design	Inherently pressure-tight (IS)					
Maximum permitted pressure PS	16 bar					
Maximum inlet pressure $p_{U \max}$	16 bar					
	Regulator system RE 1			Regulator system RE 2		
	Setpoint spring			Setpoint spring		
Specific guide range W_{ds}	Spring no.	Wire diameter (mm)	Color coding	Spring no.	Wire diameter (mm)	Color coding
20 mbar to 30 mbar	0	3.6	blue	0	5	blue
25 mbar to 50 mbar	1	4	gray	1	6.3	gray
45 mbar to 100 mbar	2	4.5	yellow	2	7	yellow
90 mbar to 200 mbar	3	5.3	brown	3	8	brown
150 mbar to 300 mbar	4	6.3	light red	4	9	light red
250 mbar to 400 mbar	5	7	dark red	5	10	dark red
350 mbar to 500 mbar	6	7.5	light blue	6	11	light blue
450 mbar to 600 mbar	7	8.5	white	7	12	white
550 mbar to 800 mbar	8	9.5	green	8	13	green
650 mbar to 1000 mbar	9	10.5	black	9	14	black
Precision class AC and closing pressure group SG Outlet pressure range p_d	AC	SG		AC	SG	
20 mbar to 30 mbar	20	50		10	30	
> 30 mbar to 100 mbar	10	30		10	20	
> 100 mbar to 500 mbar	5	20		5	10	
> 500 mbar to 1000 mbar	5	10		2.5	10	
Closing pressure zone group	SZ 2.5					
Rated width	DN 25, DN 50, DN 80, DN 100					
Connection type	Flange PN 16 ANSI 16.5 Class 150 upon request					
Material	Actuator housing and SSV Actuator housing Diaphragms; gaskets Internal parts			Cast aluminum alloy Sheet steel NBR/ECO Aluminum alloy, steel, brass		
Temperature range Class 2	Ambient and working temperature range -20°C to +60°C					
Function and resistance	according to DIN EN 334 and DIN EN 14382					
CE mark according to PED						
Type examination according to	<ul style="list-style-type: none"> • PED (DGRL) • GAD (GGRL) as equipment part for gas consumer facilities 					
Ex-protection	The mechanical components of the device themselves have no potential sources of ignition and no hot surfaces, and are therefore not subject to ATEX 95 (94/9/EC). Electronic equipment used meets ATEX requirements.					

Gaspressure regulator RMG 330

Applications, Features, Technical Data

Device metric					
Rated width	Valve seat diameter (mm)	Valve flow coefficient K_G^* in (m ³ /h)/bar		Inlet pressure range** $\Delta p_{U \max}$ (bar) for regulator	
		without noise reduction	with noise reduction	RE 1	RE 2
DN 25	20	200	180	16	-
	33	420	-	10	-
DN 50	20	200	180	16	-
	33	500	450	10	-
DN 80	25	400	370	16	16
	31	850	770	10	16
	41	1400	1200	8	16
	50	1750	-	5	10
DN 100	25	400	370	-	16
	31	850	770	-	16
	41	1400	1200	-	16
	50	1750	-	-	10
	60	3000	2700	-	10
	80	4200	3600	-	6
	100	4700	-	-	4

* Valve flow coefficient for natural gas: $d = 0.64$ ($\rho_n = 0.83$ kg/m³), $t_u = 15^\circ\text{C}$

** The maximum inlet pressure range $\Delta p_{U \max}$ is not limited for reasons of resistance, but rather to comply with the AC precision class.

Integrated safety blowout valve (leakage gas SBV) can only be used up to $p_{ds \max} = 0.5$ bar			
No.	Setpoint spring Wire diameter (mm)	Regulator system	Trigger pressure Set via p_{ds} (mbar)
1	3.5	RE 1	10 to 100
2	5		75 to 300
1	3	RE 2	15
2	3.6		40
3	4.5		130

SSV adjustment range for control unit model RMG 673, K1A/ K2A and model RMG 674 K4/ K5/ K6											
Control unit	Setpoint spring			Upper trigger pressure *		Lower trigger pressure *		Smallest re-engagement difference between the upper and lower trigger pressure with spring:			Trigger pressure group value**
	no.	Wire diameter (mm)	Color coding	Upper adjustment range W _{dso} (mbar)	Minimum re-engagement difference between the trigger pressure and normal working pressure Δp _{wo} (mbar)	Lower adjustment range W _{dsu} (mbar)	Minimum re-engagement difference between normal working pressure and the trigger pressure Δp _{wu} (mbar)	No. 5	No.6	no.7	
								(mbar)	(mbar)	(mbar)	
K1a	1	2,5	yellow	50 ... 100	30	-	-	50	70	-	10/5
	2	3,2	light red	80 ... 250	50	-	-	70	90	130	10/5
	3	3,6	dark red	200 ... 500	100	-	-	120	140	180	5/2,5
	4	4,75	white	500 ... 1500	250	-	-	290	310	330	5/2,5
	5	1,1	light blue	-	-	10 ... 15	12	-	-	-	10
	6	1,2	white	-	-	14 ... 40	30	-	-	-	10/5
	7	1,4	black	-	-	35 ... 120	60	-	-	-	5
K2a	2	3,2	light red	400 ... 800	100	-	-	-	-	-	10/5
	3	3,6	dark red	600 ... 1600	200	-	-	-	-	-	10/5
	4	4,75	white	1500 ... 4500	300	-	-	-	-	-	5/2,5
	5	1,1	light blue	-	-	60 ... 150	50	-	-	-	10/5
	7	1,4	black	-	-	120 ... 400	100	-	-	-	5
K4	2	3,2	light red	40 ... 100	20	-	-	45	55	-	5/2,5
	3	3,6	dark red	80 ... 250	30	-	-	55	65	-	2,5
	4	4,5	black	200 ... 500	60	-	-	85	95	-	2,5/1
	5	1,1	light blue	-	-	5 ... 20	10	-	-	-	10/5
	6	1,4	black	-	-	15 ... 60	20	-	-	-	5
	7	1,4	black	-	-	15 ... 60	20	-	-	-	5
K5	5	3,6	dark red	200 ... 800	100	-	-	170	200	-	2,5
	6	4,5	black	600 ... 1500	200	-	-	270	300	-	2,5/1
	5	1,1	light blue	-	-	15 ... 50	30	-	-	-	10/5
	6	1,4	black	-	-	40 ... 120	60	-	-	-	10/5
K6	3	3,6	dark red	600 ... 2000	200	-	-	-	-	-	2,5
	4	4,5	black	1500 ... 4500	400	-	-	-	-	-	2,5/1
	5	1,1	light blue	-	-	40 ... 120	60	-	-	-	10/5
	6	1,4	black	-	-	120 ... 300	120	-	-	-	5

* NOTE: If the control unit is set up for an upper and lower trigger pressure at the same time, the difference between the setpoints of the upper and lower trigger pressure (p_{dso} and p_{dsu}) must be at least 10% greater than the total of the values specified for Δp_{wo} und Δp_{wu}

$$(p_{dso} - p_{dsu})_{min} = 1.1 \cdot (\Delta p_{wo} + \Delta p_{wu})$$

** The higher group of values applies to the first half, while the lower group of values applies to the second half of the adjustment range.

Gaspressure regulator RMG 330

Structure and operation

RMG 330, DN 25, and DN 50

optionally with
RMG 915 breathing valve

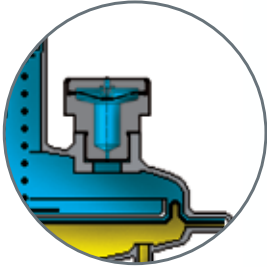

optionally with
Breathing valve
RMG 915

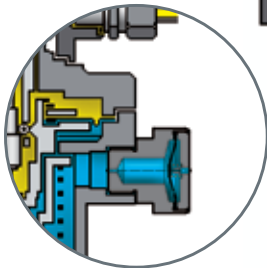

- Inlet pressure
- Outlet pressure
- Atmosphere

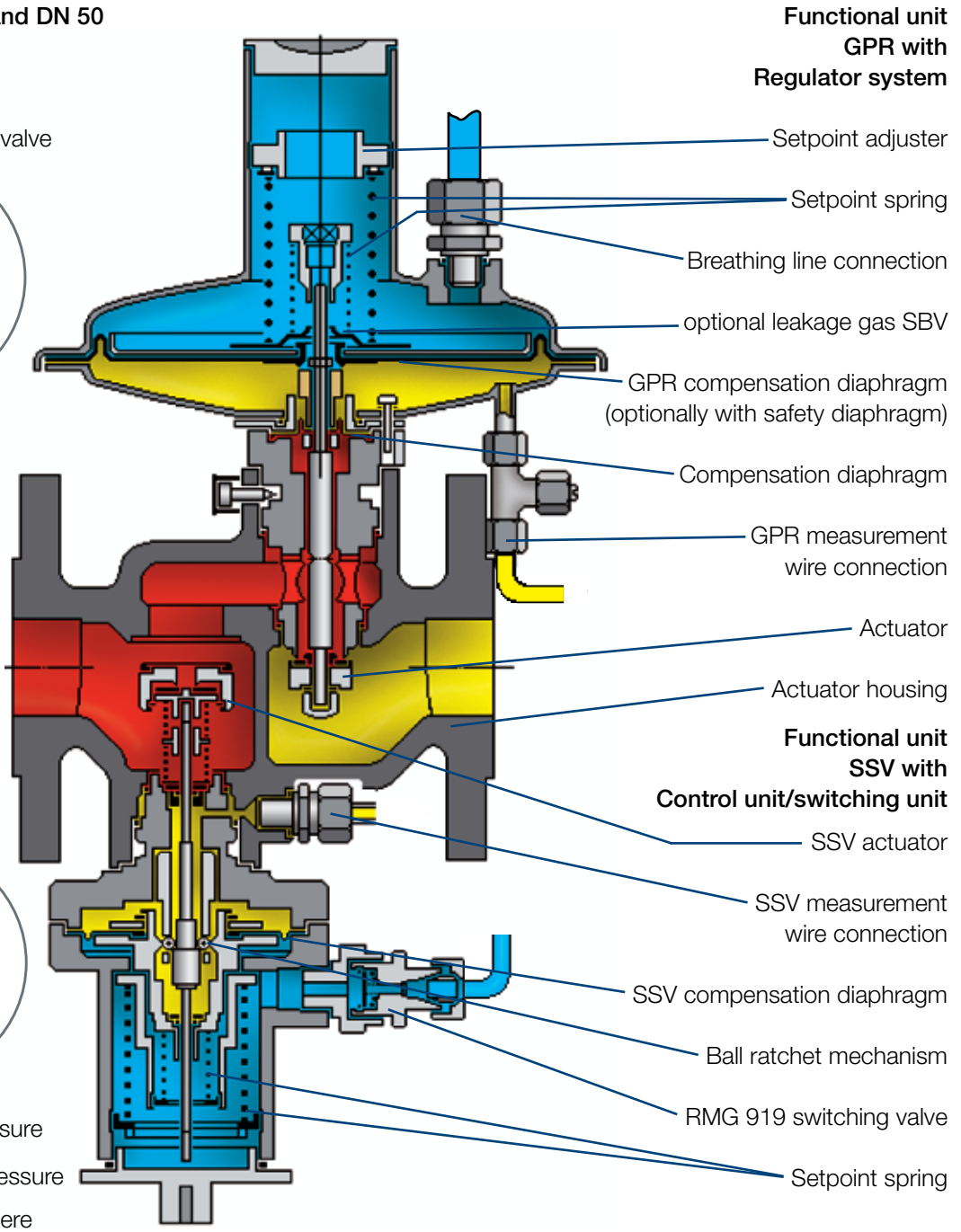

Functional unit
GPR with
Regulator system

Functional unit
SSV with
Control unit/switching unit

The direct-acting (working without auxiliary power) RMG 330 gas pressure regulator has the task of keeping the outlet pressure of a gaseous medium in a connected outlet side pipeline (regulated segment) largely constant, independent of interfering influences such as changes in inlet pressure and/or gas takeoff. The regulator consists of an actuator housing and the functional units "GPR with regulation system" and SSV controller/switching unit. After the screw fasteners are loosened, the complete functional unit can easily be removed from the "GPR actuator housing" and subjected to a visual inspection during maintenance rounds. In case of a defect, it is possible to replace the functional units quickly with tested replacement units and move the required maintenance work from the gas pressure regulator into the workshop.

The actuator of the regulator system can have different valve seat diameters. The valve seat variants are pressure-equalized. Regulator system can optionally be equipped with a leakage gas SBV or a safety diaphragm. The outlet pressure to be regulated is guided to the GPR regulator system and the SSV controller via measurement lines.

RMG 330, DN 80, and DN 100

Functional unit

GPR with regulator system

Setpoint adjuster

Setpoint spring

optionally
leakage gas SBV

GPR compensation diaphragm
(optionally with safety diaphragm)

Compensation diaphragm

Actuator

Actuator housing

Functional unit
SSV with Control unit/
switching unit

SSV actuator

SSV compensator diaphragm

Ball ratchet mechanism

Setpoint spring

Breathing line
connection

optionally with
Breathing valve
RMG 915

GPR measurement
wire connection

SSV measurement
wire connection

RMG 919 switching valve

optionally with
Breathing valve
RMG 915

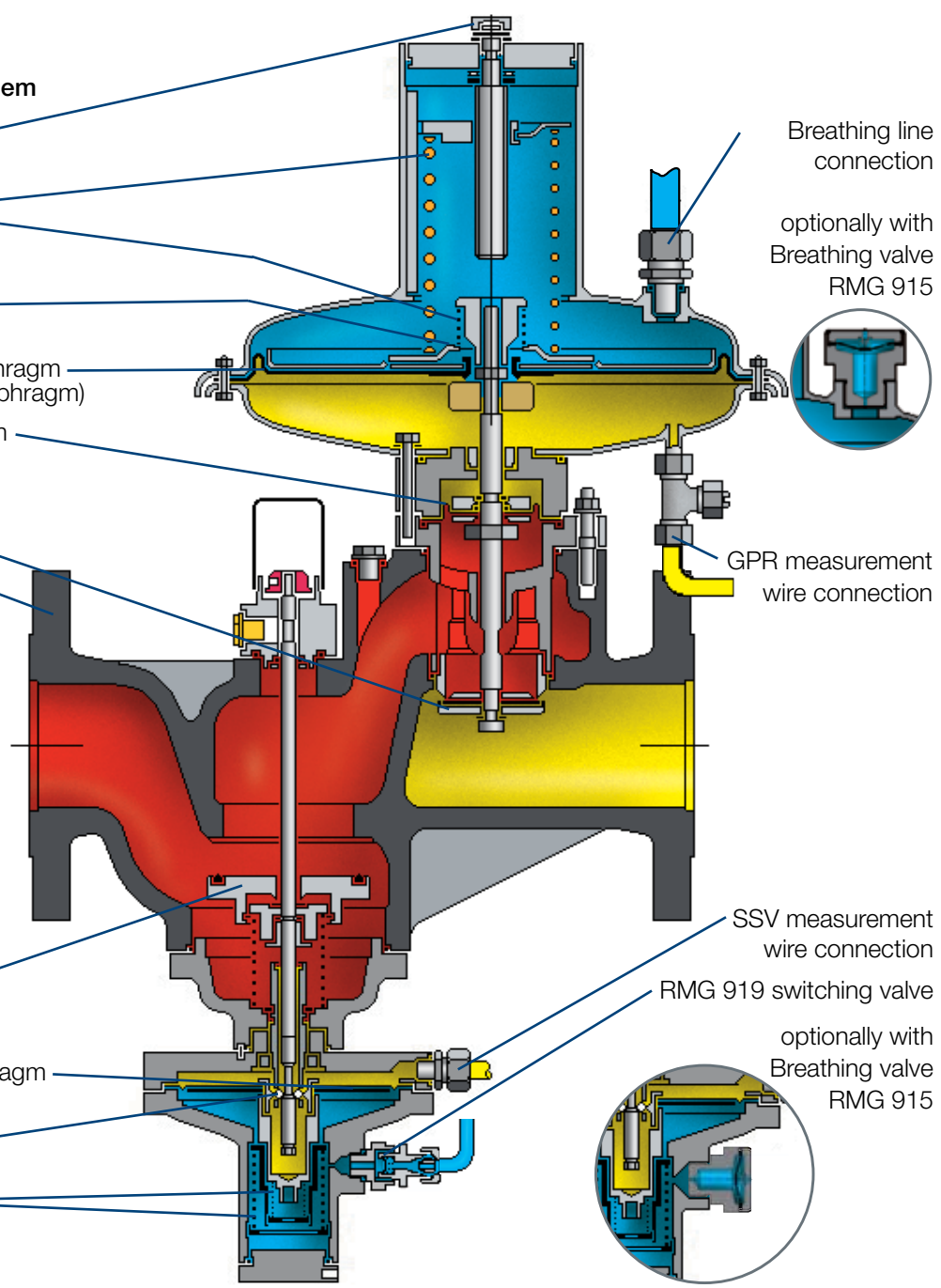

The compensation diaphragm of the regulator records the actual value of the outlet pressure and compares it with the set value specified by the setpoint spring. A regulation deviation has a direct influence through the valve rod to the actuator position. The resulting change in flow causes an equalization of the actual outlet pressure value with the setpoint. At zero consumption, the device seals tight and the closing pressure is set.

The actuator of the safety blocking valve on the inlet side blocks the gas flow when the outlet pressure in the regulated segment exceeds or falls below a certain trigger pressure. In this process, the SSV measurement diaphragm with the switch sleeve moves into the appropriate ratchet position, the ball ratchet mechanism releases the SSV valve rod, and the SSV actuator closes. The SSV can only be ratcheted into the open position by hand when the outlet pressure at the measurement point differs from the trigger pressure setpoint by the specified re-engagement differences for excess pressure and pressure deficit. The SSV can optionally also be equipped with a manual and a remote trigger. It can optionally also be designed in function class A (with diaphragm break safety) or B (without diaphragm break safety).

Gaspressure regulator RMG 330

Dimensions, connection, weight

RMG 330, DN 25, and DN 50

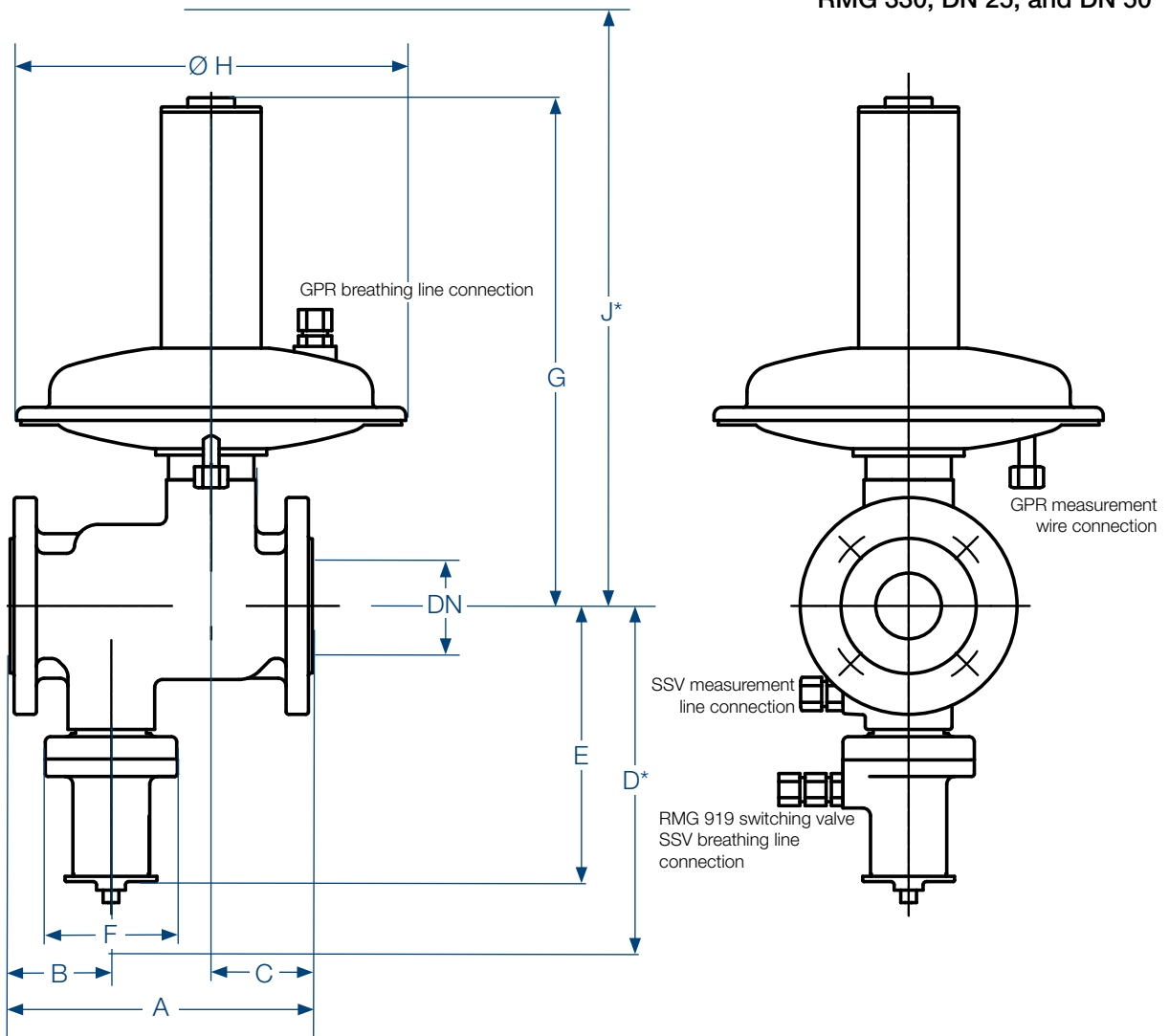

*) Size when assembled

Dimensions (mm)												
DN	Actuator housing			Safety blocking valve			Regulator with regulator system					
	A	B	C	D*	E	Ø F	G	RE 1		RE 2		
								Ø H	J*	G	Ø H	J*
25	200	66	66	350	230	Max.	385	297	510			
50	230	77	77			130						
80	420	165	127	580	360	Max.	450		560	600	395	710
100	500	175	150	580	330	180						

Connection to measurement lines and breathing lines			
	Actuator		SSV control unit/switching unit
	Measurement line	Breathing/blowout line	
RE 1	Connection* for: 12 x 1.5 pipe (12 x 1.5 pipe on unit)	Connection* for: 12 x 1.5 pipe (G 1/2 thread)	Connection* for: 12 x 1.5 pipe (M 16 x 1.5 thread)
RE 2	Connection* for: 16 x 2 pipe (16 x 2 pipe on unit)	Connection* for: 12 x 1.5 pipe (G 1/2 thread)	

* DIN EN ISO 8434-1 (DIN 2353) compliant pipe screw fittings

Connection fastening element:

DN 25 M 12 x 55 EN 24014 - 5.6 screws

DN 50 to 100 M 16 x 70 EN 24014 - 5.6 screws

RMG 330, DN 80, and DN 100

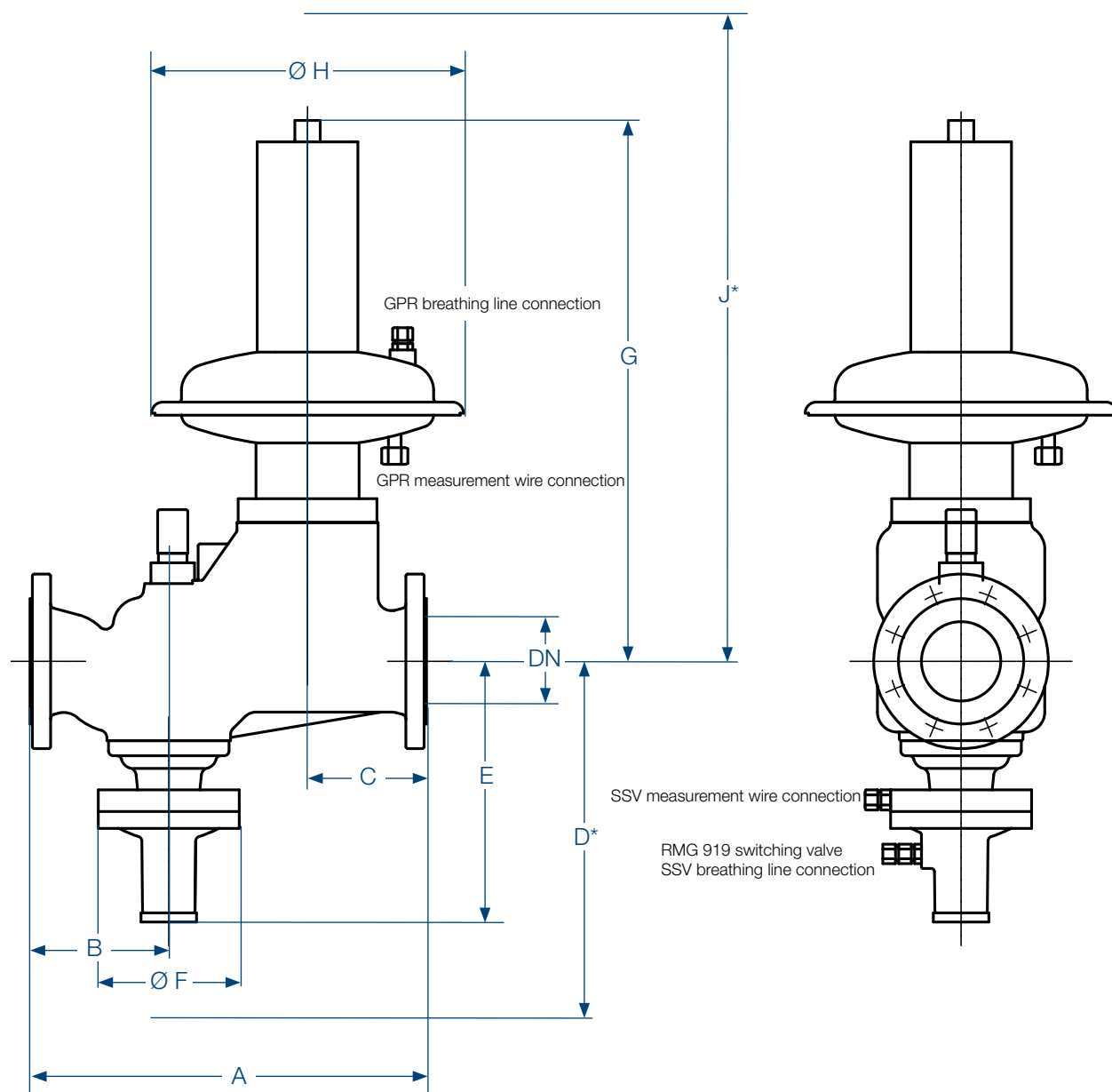

*) Size when assembled

approximate Weight (kg)				
Gas pressure regulator with regulator system				
DN	RE 1		RE 2	
	with SSV	without SSV	with SSV	without SSV
25	10,5	9,5	-	-
50	12	11	-	-
80	28	21	42	35
100	-	-	46	39

Gaspressure regulator RMG 330

Unit description

80	RE 2 SBV blocked	25	25	2
		31	31	
		41	41	
		50	50	
		50	25	
	RE 2 with SBV	31	31	2L
		41	41	
		50	50	
		25	25	
		31	31	
RE 2 with SM	41	41	2 S	
	50	50		
	25	25		
	31	31		
	50	50		
RE 2 SBV blocked	25	25	2	
	31	31		
	41	41		
	50	50		
	60	60		
	80	80		
	100	100		
	25	25		
	31	31		
	41	41		
RE 2 with SBV	50	50	2L	
	60	60		
	80	80		
	100	100		
	25	25		
	31	31		
	41	41		
	50	50		
	60	60		
	80	80		
RE 2 with SM	60	60	2S	
	80	80		
	100	100		
	25	25		
	31	31		
	41	41		
	50	50		
	60	60		
	80	80		
	100	100		
Specific Guide range				
W/Ds		Setpoint spring no.		
20 mbar to 30 mbar		0		0
25 mbar to 50 mbar		1		1
45 mbar to 100 mbar		2		2
90 mbar to 200 mbar		3		3
150 mbar to 300 mbar		4		4
250 mbar to 400 mbar		5		5
350 mbar to 500 mbar		6		6
450 mbar to 600 mbar		7		7
550 mbar to 800 mbar		8		8
650 mbar to 1000 mbar		9		9

Gas pressure control valve RMG 330

Unit description

Rated width					
DN 25				25	
DN 50				50	
DN 80				80	
DN 100				100	
Control unit		Adjustment range in bar			
	Wdo	Wdu			
K1a	0.05 to 1.5	0.01 to 0.12		K1a	
K2a	0.4 to 4.5	0.06 to 0.4		K2a	
K4	0.04 to 0.5	0.005 to 0.06		K4	
K5	0.2 to 1.5	0.015 to 0.12		K5	
K6	0.6 to 4.5	0.04 to 0.3		K6	
Function class					
A				A	
B				B	
Electromagnetic remote trigger		Triggering on:		Power applied / power failure	E1 / E2
Manual triggering		Manual triggering with RMG 912 touch valve			HA
Remote transmission		Electrical remote transmission of valve position "Closed"			F
Regulator system					
DN		Size	Valve		
25 / 50	RE 1	20	20	20	1
		33	33	33	
	SBV blocked	20	20	20	1L
		33	33	33	
	RE 1 with SBV	20	20	20	1S
		33	33	33	
	RE 1 with SM	25	25	25	1
		33	33	33	
	RE 1 SBV blocked	31	31	31	1L
		41	41	41	
RE 1 with SBV	31	31	31	1S	
	41	41	41		
RE 1 with SM	25	25	25	1	
	31	31	31		
RE 1 with SM	41	41	41	1S	
	50	50	50		

RMG 330 - 50 - K1a / A / E1 / HA / F - 33 / 1 L / 3 - So

Type

Rated width

Control unit

Function class

Electromagnetic remote trigger

Manual triggering

Remote transmission

Valve seat diameter

Regulator system

Setpoint spring

Special design (must be specified in detail)

Further information

If you would like to know more about RMG's solutions for the gas industry, please get in touch with your local contact or visit our Internet site www.rmg.com

GERMANY

Honeywell Process Solutions

RMG Regel + Messtechnik GmbH
Osterholzstrasse 45
34123 Kassel, Germany
Tel: +49 (0)561 5007-0
Fax: +49 (0)561 5007-107

Honeywell Process Solutions

RMG Messtechnik GmbH
Otto-Hahn-Strasse 5
35510 Butzbach, Germany
Tel: +49 (0)6033 897-0
Fax: +49 (0)6033 897-130

Honeywell Process Solutions

RMG Gaselan Regel + Messtechnik GmbH
Julius-Pintsch-Ring 3
15517 Fürstenwalde, Germany
Tel: +49 (0)3361 356-60
Fax: +49 (0)3361 356-836

Honeywell Process Solutions

WÄGA Wärme-Gastechnik GmbH
Osterholzstrasse 45
34123 Kassel, Germany
Tel: +49 (0)561 5007-0
Fax: +49 (0)561 5007-207

POLAND

Honeywell Process Solutions

Gazomet Sp. z o.o.
ul. Sarnowska 2
63-900 Rawicz, Poland
Tel: +48 (0)65 5462401
Fax: +48 (0)65 5462408

ENGLAND

Honeywell Process Solutions

Bryan Donkin RMG Gas Controls Ltd.
Enterprise Drive, Holmewood
Chesterfield S42 5UZ, England
Tel: +44 (0)1246 501-501
Fax: +44 (0)1246 501-500

CANADA

Honeywell Process Solutions

Bryan Donkin RMG Canada Ltd.
50 Clarke Street South, Woodstock
Ontario N4S 0A8, Canada
Tel: +1 (0)519 5398531
Fax: +1 (0)519 5373339

USA

Honeywell Process Solutions

Mercury Instruments LLC
3940 Virginia Avenue
Cincinnati, Ohio 45227, USA
Tel: +1 (0)513 272-1111
Fax: +1 (0)513 272-0211

TÜRKEY

Honeywell Process Solutions

RMG GAZ KONT. SIS. ITH. IHR. LTD. STI.
Birlik Sanayi Sitesi, 6.
Cd. 62. Sokak No: 7-8-9-10
TR - Sasmaz / Ankara, Turkey
Tel: +90 (0)312 27810-80
Fax: +90 (0)312 27828-23